

GUIDANCE NOTES

GD 16-2018



**ISClass**

INTERNATIONAL SHIP CLASSIFICATION

GUIDELINES FOR COMBINED INSPECTION OF  
TIME-OF-FLIGHT DIFFRACTION (TOFD) AND  
PHASED ARRAY ULTRASONIC TESTING (PAUT)  
TECHNIQUES FOR MARINE THICK PLATE WELD  
JOINTS

2018

Effective from 1 Oct. 2018



**ISClass**

**INTERNATIONAL SHIP CLASSIFICATION**

**GUIDELINES FOR COMBINED INSPECTION OF  
TIME-OF-FLIGHT DIFFRACTION (TOFD) AND  
PHASED ARRAY ULTRASONIC TESTING (PAUT)  
TECHNIQUES FOR MARINE THICK PLATE WELD  
JOINTS**

**2018**

## CONTENTS

<b>CHAPTER 1 GENERAL .....</b>	<b>2</b>
1.1 Purpose.....	2
1.2 Scope of application.....	2
1.3 Class notation.....	2
1.4 Terms and definitions .....	2
1.5 Testing organizations and personnel.....	5
<b>CHAPTER 2 GENERAL REQUIREMENTS.....</b>	<b>6</b>
2.1 Testing system .....	6
2.2 Periodical calibration of the equipment.....	9
2.3 Testing procedures.....	10
<b>CHAPTER 3 SELECTION AND SET-UP OF TESTING PROCEDURE PARAMETERS .....</b>	<b>12</b>
3.1 Test area .....	12
3.2 Design of testing procedures.....	12
<b>CHAPTER 4 TESTING REQUIREMENTS.....</b>	<b>14</b>
4.1 General requirements.....	14
4.2 Equipment set-up .....	14
4.3 TOFD system configuration.....	15
4.4 PAUT system configuration .....	16
4.5 Test implementation .....	16
<b>CHAPTER 5 TEST DATA ANALYSIS AND INTERPRETATION.....</b>	<b>19</b>
5.1 Evaluation of data validity.....	19
5.2 Relevant indications and irrelevant indications.....	19
<b>CHAPTER 6 ASSESSMENT OF FLAWS AND QUALITY CLASSIFICATION .....</b>	<b>20</b>
6.1 General requirements.....	20
6.2 Assessment of flaws of TOFD.....	20
6.3 Assessment of flaws of PAUT.....	21
6.4 Quality classification .....	21
<b>CHAPTER 7 TESTING RECORDS AND REPORTS .....</b>	<b>26</b>
7.1 Testing records and reports.....	26
7.2 Storage and filing of testing data.....	26
<b>APPENDIX A TESTING FOR TRANSITION WELDS .....</b>	<b>27</b>
<b>APPENDIX B TYPICAL TOFD IMAGING AND METHODS OF FLAW MEASUREMENT .....</b>	<b>29</b>
<b>APPENDIX C SAMPLE OF COMBINED INSPECTION REPORT OF TOFD AND PAUT .....</b>	<b>37</b>

## CHAPTER 1 GENERAL

### 1.1 Purpose

1.1.1 The Guidelines are developed to provide reference when the combined inspection of time-of-flight diffraction (TOFD) and phased array ultrasonic testing (PAUT) techniques is used to carry out NDT for butt welds in thick plates of ship structure/members.

### 1.2 Scope of application

1.2.1 The thick plates in the Guidelines mean marine steel plates with nominal thickness not less than 30 mm.

1.2.2 The Guidelines apply to weld joints satisfying the following conditions at the same time:

- (1) both the weld and base metal are low-carbon steel or low-alloyed high-strength steel;
- (2) joints are full penetration butt joints;
- (3) material thickness  $t$ :  $30 \text{ mm} \leq t \leq 100 \text{ mm}$  (In case of different base metal thickness at either side of the weld, the base metal thickness of the thinner side is to be taken).

1.2.3 For using TOFD or PAUT technique separately, see ISC Guidelines for the Application of Time-of-Flight Diffraction (TOFD) and Phased Array Ultrasonic Testing (PAUT) Techniques.

### 1.3 Class notation

1.3.1 When the combined inspection of time-of-flight diffraction (TOFD) and phased array ultrasonic testing (PAUT) techniques is used, TOFD and PAUT-Butt class notations may be assigned respectively upon application by the ship owner in accordance with the Guidelines for the Application of Time-of-Flight Diffraction (TOFD) and Phased Array Ultrasonic Testing (PAUT) Techniques.

### 1.4 Terms and definitions

1.4.1 Terms and definitions used in the Guidelines are as follows:

- (1) Time-of-Flight Diffraction (TOFD) technique is an ultrasonic testing technique using one transmitting probe and one receiving probe to detect, locate and size up flaws mainly relying on the diffraction wave signals.
- (2) Scanning surface is the object surface on which the probes are laid and scanning is carried out.
- (3) Back wall is the other object surface opposite to the scanning surface.
- (4) Lateral wave is the ultrasonic wave that travels by the most direct route along the object from the transmitting probe to the receiving probe.
- (5) Back wall echo is the ultrasonic wave reflected to the receiving probe from the transmitting probe through the back wall.
- (6) Probe center separation (PCS) is the straight-line distance between the theoretical ultrasonic exit point of the transmitting probe and the theoretical ultrasonic entry point of the receiving probe.
- (7) Parallel scan is a scan whereby the probe pair motion is parallel to the beam axis, generally referring to the scan whereby the probes are moving along y-axis, see Figure 1.4.1(a).

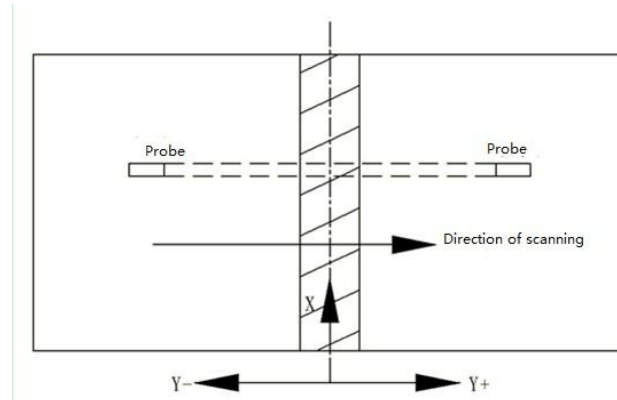

**Figure 1.4.1(a) Parallel Scan**

(8) Non-parallel scan is a scan whereby the probe pair motion is perpendicular to the beam axis, generally referring to the scan whereby the probes are symmetrically located on both sides of the centerline of the weld moving along the weld length (x-axis), see Figure 1.4.1(b).

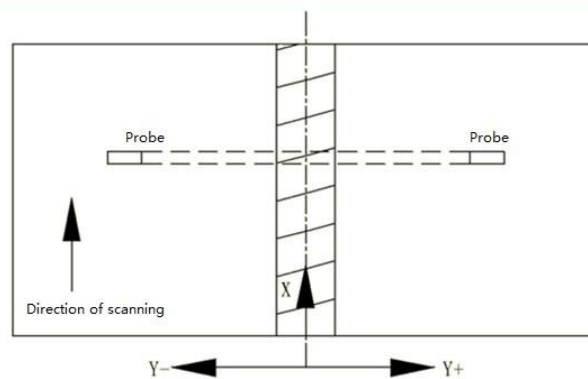

**Figure 1.4.1(b) Non-Parallel Scan**

(9) Offset non-parallel scan is an asymmetric scan whereby symcenter of the probes is at a certain distance from the centerline of the weld, see Figure 1.4.1(c).

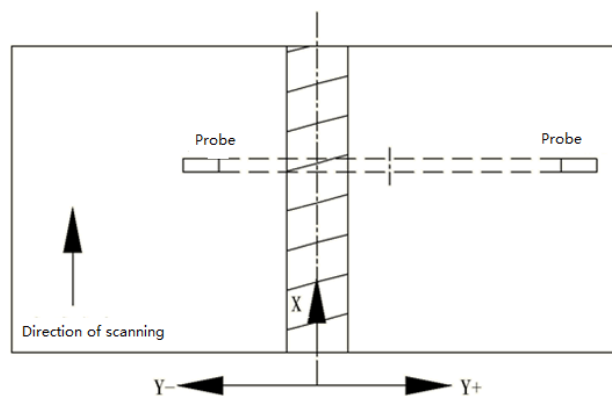

**Figure 1.4.1(c) Offset Non-Parallel Scan**

(10) Inclined scan is a scan whereby the probe pair motion is along x-axis and the connection line of the probes is at 30° to 60° from the centerline of the weld, see Figure 1.4.1(d).

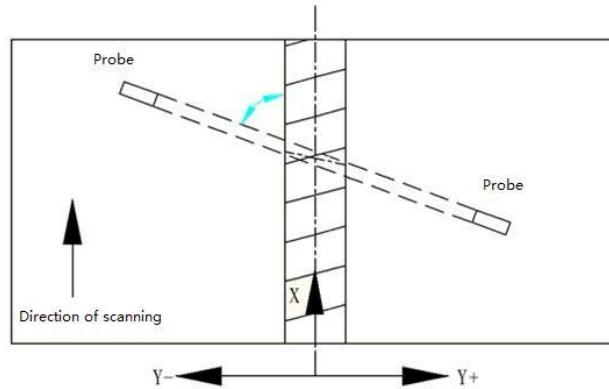

**Figure 1.4.1(d) Inclined Scan**

(11) Scanning-surface dead zone is a zone where the scanning surface cannot be tested due to the width of the lateral wave as well as shape and structure of the object, generally indicated by not being able to detect the maximum value of the flaw height on the scanning surface in the scanned zone.

(12) Back wall dead zone is a zone where the back wall cannot be tested due to axial displacement during non-parallel scan or offset non-parallel scan, generally indicated by not being able to detect the maximum value of the flaw height on the back wall in the scanned zone.

(13) TOFD image is a two-dimensional image, constructed by collecting adjacent A-scans while moving the time-of-flight diffraction setup. One axis represents the moving distance of the probes while the other axis represents the depth. Generally gray scale is used to represent the amplitude of the A-scans.

(14) Phased Array Ultrasonic Testing (PAUT) is an ultrasonic testing technique based on the set focal law to apply different time delay (or voltage) when each element of the phased array probes is transmitting or receiving sound beam thus realizing the functions of testing the movement, deflection and focusing of the sound beam by forming wave beam.

(15) Sectorial scan (S-scan) is a scan using specific focal law to excite part of adjacent elements or all elements in the phased array probes so that the sound beam formed by the excitation element group scans the sectorial area by changing the angle at certain increment within the set angle range.

(16) Focal law is the algorithm or relevant procedures to realize beam deflection and focusing by controlling the number of excitation elements as well as the transmitting and receiving delay applied to each element.

(17) Probe position is the distance between the front of the probe and the weld centerline.

(18) Scan increment is the distance between successive data collection points in the direction of scanning.

(19) Scanning increment is the angle difference between the adjacent wave beams in the sectorial scanning or position difference between the adjacent wave beams in linear scanning.

(20) Relevant indication is the indication caused by flaw in the scanning image.

(21) Non-relevant indication is the indication caused by structure of the object or deviation in metallurgical composition of the material in the scanning image.

(22) Coordinate definition specifies starting reference point O for testing and the meanings of coordinates X, Y and Z, see Figure 1.4.1(e).

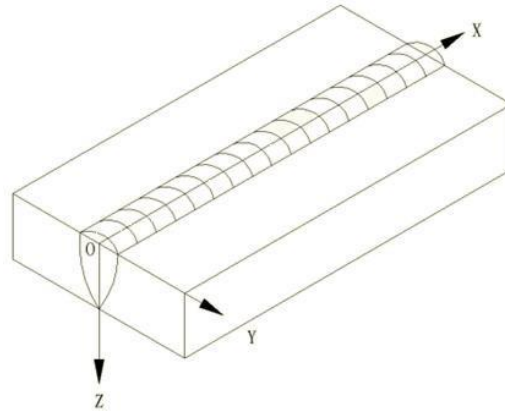

Where:

- O—Preset starting reference point for testing
- Y—Coordinate along the weld width
- X—Coordinate along the weld length
- Z—Coordinate along the weld thickness

**Figure 1.4.1(e) Coordinate Definition**

## **1.5 Testing organizations and personnel**

1.5.1 Organizations engaged in TOFD and PAUT are to have organization qualification approved by ISC.

1.5.2 Testing personnel are to be furnished with PAUT or TOFD certificates accepted by ISC and can only carry out testing within the qualification scope specified by their certificates. Testing personnel are to demonstrate their familiarity with the procedural requirements as well as testing equipment by procedural verification activities specified in 2.3.3 of the Guidelines.

1.5.3 Personnel with TOFD I or PAUT I qualification can adjust and operate equipment, carry out on-site testing and recording according to procedure specifications and operation guidance.

1.5.4 Personnel with TOFD II or PAUT II qualification can develop procedure specifications and operation guidance, set equipment parameters, calibrate the equipment, collect and record data on site, interpret data, issue reports, guide and supervise the operation of personnel with level I qualification.

1.5.5 Personnel with TOFD III or PAUT III qualification can develop, verify and review procedure specifications and operation guidance, interpret rules, standards, technical conditions and procedure specifications, implement and supervise the operation of personnel with level I and II qualification.

## CHAPTER 2 GENERAL REQUIREMENTS

### 2.1 Testing system

#### 2.1.1 Testing equipment

2.1.1.1 The equipment is to be furnished with a product quality certificate or a quality document issued by the manufacturer, as well as calibration report produced by the manufacturer or metrology department approved by the State, and it is to be within the valid calibration period.

2.1.1.2 The TOFD equipment is, as a minimum, to provide a means of transmitting, receiving, amplifying, storing, recording, displaying and analyzing ultrasonic signals. The equipment is to have sufficient channels so as to carry out multi-channel testing and it is, as a minimum, to satisfy the following performance indicator requirements:

(1) The transmitting pulse can either be unipolar, bipolar sharp or square. The rise time is not to exceed 0.25 times the nominal probe frequency.

(2) The pulse width of the equipment is to be tunable to allow optimization of pulse amplitude and duration. The pulse width adjusting increment is not to be more than 10 ns.

(3) The pulse repetition frequency of the equipment is to be tunable with the maximum value not less than 500 Hz.

(4) The equipment is to have sufficient voltage to ensure the testing system have sufficient sensitivity and signal-to-noise ratio.

(5) The bandwidth of the receiver is at least not to be less than that of the nominal probe bandwidth and such that the -6 dB bandwidth of the probe does not fall outside of -6 dB bandwidth of the receiver.

(6) The system is to have sufficient gain which is to be continuously adjustable in increment of 1 dB or less.

(7) Digitized sampling frequency is at least to be eight times the nominal probe frequency.

(8) Sampling digit is at least to be 8.

(9) The number of grey scales is at least to be 256.

(10) Initial delay of A-scan signal is to be programmable between 0 and 200  $\mu$ s, and window length is to be programmable between 5 and 100  $\mu$ s.

(11) The equipment is to be capable of performing signal averaging, the maximum averaging number being not less than 8.

(12) The equipment is to have position encoding function.

(13) The equipment software is to include algorithms to linearize depth cursors or permit depth estimations.

(14) The equipment is to be capable of copying all collected raw data in a tamper-proof manner.

(15) The equipment is to be capable of using software to process data (such as lateral wave synchronization, lateral wave differentiation, SAFT, etc.) without changing the raw data.

2.1.1.3 The PAUT equipment is, as a minimum, to have ultrasound transmitting, receiving, amplifying, data collection, recording, indication and analysis functions, and to satisfy the following performance indicator requirements:

(1) The transmitting pulse can either be unipolar, bipolar sharp or square. The rise time is not to exceed 0.25 times the nominal probe frequency.

(2) The pulse width of the equipment is to be tunable to allow optimization of pulse amplitude and

duration. The pulse width adjusting increment is not to be more than 10 ns.

(3) The pulse repetition frequency of the equipment is to be tunable with the maximum value not less than 500 Hz.

(4) The equipment is to have sufficient voltage to ensure the testing system have sufficient sensitivity and signal-to-noise ratio.

(5) The bandwidth of the receiver is at least to be equal to that of the nominal probe bandwidth and such that the -6 dB bandwidth of the probe does not fall outside of -6 dB bandwidth of the receiver.

(6) The system is to have sufficient gain which is to be continuously adjustable in increment of 1 dB or less.

(7) Digitized sampling frequency is at least to be eight times the nominal probe frequency.

(8) Sampling digit is at least to be 8.

(9) The number of color or pseudo color scales is at least to be 256.

(10) Initial delay of A-scan signal is to be programmable between 0 and 200  $\mu$ s, and window length is to be programmable between 5 and 100  $\mu$ s.

(11) The equipment is to have position encoding function.

(12) The equipment software is to have focal law calculation function.

(13) The software is, as a minimum, to have A, B, C, D, S, E viewing or imaging modes.

(14) The equipment is to have internal compensation function to carry out ACG and TCG/DAC calibration.

(15) The equipment is recommended to have video smoothing function.

(16) The equipment is to be capable of copying all collected raw data in a tamper-proof manner.

#### 2.1.2 Probes

2.1.2.1 All probes used are to have factory inspection report and quality certificate.

2.1.2.2 The probe inspection report is, as a minimum, to include information of the probe such as element size, centre frequency, bandwidth at -6 dB. Phased array probes are also to have testing parameters such as element distribution as well as element consistency.

#### 2.1.3 Wedges

2.1.3.1 Wedges are to have factory inspection report.

2.1.3.2 The inspection report is to specify the design parameters of the wedge, such as sound velocity, theoretical refraction angle, element position, etc. TOFD wedges are to be marked with theoretical beam exit point.

#### 2.1.4 Scanning mechanism

Scanning mechanism is in general to include probe holding device, guiding part, driving part and position recording part.

2.1.4.1 The probe holding part is to be capable of adjusting probe position and distance and maintaining the relative position of the probes during scanning.

2.1.4.2 The guiding part is to be capable of guiding the scanning mechanism in the pre-set track.

2.1.4.3 The driving part can either be motor or manually driven.

2.1.4.4 The accuracy of the position recording part is to satisfy the requirements for data collection of the Guidelines.

#### 2.1.5 Combination performance of the testing equipment

The combination performance of the testing equipment is to satisfy the following requirements:

(1) the horizontal linear error is not more than 1%;

- (2) the vertical linear error is not more than 5%;
- (3) the dynamic range is not less than 26 dB;
- (4) the sensitivity allowance is not less than 42 dB.

2.1.6 Couplants

2.1.6.1 The couplant is to maintain stable and reliable ultrasound characteristics in the operating temperature range.

2.1.6.2 The couplant is not to be harmful to operators and environment.

2.1.6.3 The couplant used for calibration is to be the same as that used in subsequent testing.

2.1.7 Blocks

2.1.7.1 Standard test blocks are blocks used to test the performance of the equipment probes. In the Guidelines standard test blocks are CSK-IA blocks.

2.1.7.2 Reference blocks are blocks used to calibrate sensitivity and are to comply with the following requirements as a minimum:

- (1) When the zone where the ultrasonic beam might pass through in the block material is tested by the straight probe, flaw equivalent  $\geq \text{Ø}2$  mm flat bottom hole is not allowed.
- (2) The reference block is to be made of materials with same or similar acoustic performance to the test object.
- (3) For objects having a curvature radius  $\geq 150$  mm, a flat reference block may be used. For objects having a curvature radius  $< 150$  mm, a curved reference block is to be used. Curved reference blocks are to have curvature radius from 0.9 to 1.5 times the object curvature radius.
- (4) Flat TOFD reference blocks specified by the Guidelines are shown in Figure 2.2.7.2(1).

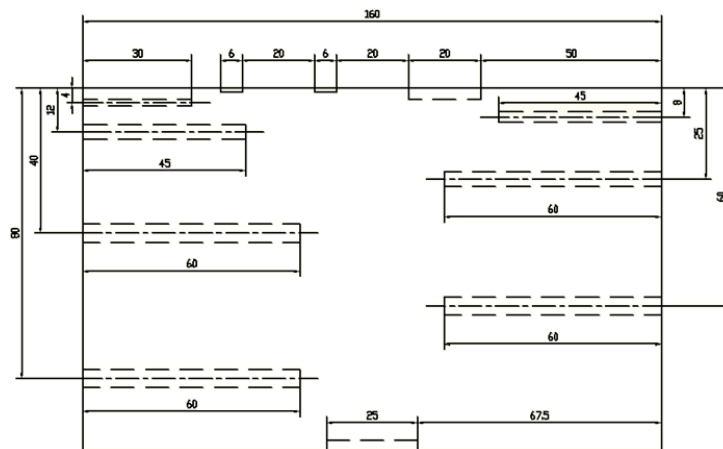

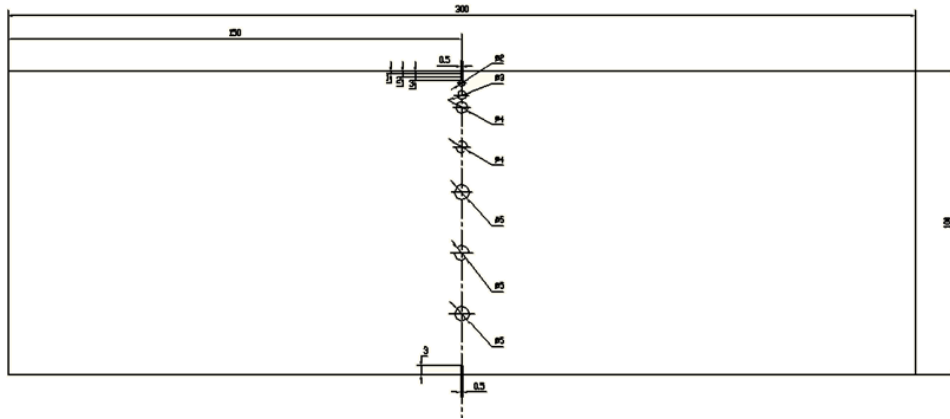

Note: hole error is not more than  $\pm 0.02$  mm, hole verticality error is not more than  $\pm 0.1^\circ$ , and other errors are not more than  $\pm 0.05$  mm.

**Figure 2.2.7.2(1) Flat TOFD Reference Block**

(5) Recommended flat PAUT reference blocks are shown in Figure 2.2.7.2(2). The type of the reference block may be designed in accordance with needs but all the functions of the block are at least to be achieved.

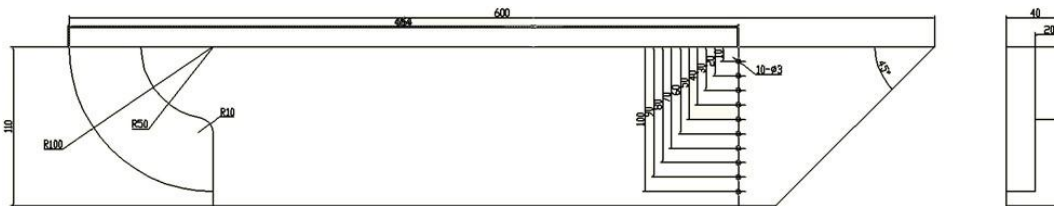

**Figure 2.2.7.2(2) Flat PAUT Reference Block**

2.1.7.3 Simulated verification blocks are to comply with the following requirements:

- (1) Simulated flaws in the simulated verification block are to be prepared by actual welding procedures or to use the actual flaw found in the previous testing. Simulated verification blocks are to have thickness from 0.9 to 1.3 times the object thickness with the maximum difference not exceeding 25 mm.
- (2) The simulated block is, as a minimum, to include two flaws on both top and bottom surfaces and one embedded flaw respectively. During zone testing, each zone is to include at least one flaw.
- (3) The flaws in the simulated block are to cover flaw types such as transverse flaw, longitudinal flaw, volume type flaw and area type flaw.
- (4) The size of the flaws in the simulated block is not to be larger than level I acceptance requirements of TOFD acceptance criteria.
- (5) In case where one block cannot cover the flaws required above, several blocks can be used in combination.

## 2.2 Periodical calibration of the equipment

2.2.1 The horizontal linearity, vertical linearity and attenuator linearity of the equipment is to be periodically calibrated and recorded. The maximum calibration cycle is not to exceed one year.

2.2.2 The attenuator linearity of each independent transmitting and receiving channel of TOFD

and PAUT equipment is to be carried out separately.

2.2.3 During each system debugging, the accuracy of the position sensor (encoder) is to be calibrated. The calibration length is not to be less than 500 mm, and the error is not to be more than 1%.

## 2.3 Testing procedures

### 2.3.1 General requirements

2.3.1.1 Testing procedure specification specific to the project is to be developed before testing. The testing procedure specifications are to be developed according to the Guidelines and submitted to ISC. Where key elements are changed, the testing procedure specifications are to be modified and resubmitted to ISC. Key elements are detailed in Table 2.3.1.

No.	Relevant elements
1	Scope of the product (object size, specification, material, wall thickness, etc.)
2	Standards and regulations that are based upon
3	Testing system as well as calibration, review, operation review or inspection requirements
4	Testing procedures (probe configuration, scanning mode, thickness zones, etc.)
5	Surface preparation requirements prior to testing
6	Dead zone testing technique and procedural testing report
7	Transverse flaw testing technique and procedural testing report
8	Analysis and interpretation of the test data
9	Flaw evaluation and quality classification

### 2.3.2 Testing procedure cards

2.3.2.1 Testing procedure cards specific to different structures are to be developed according to the approved testing procedure documents. Testing personnel are to carry out testing of specific structures according to the requirements on the cards and surveyors are to supervise the on-site operation according to the contents of the cards. The cards are to include the following as a minimum:

- (1) implementation standard, verification level, test timing, spot test rate, surface requirements;
- (2) equipment, probe, type and production serial number of the block;
- (3) wedge, scanning mechanism, name of couplant;
- (4) scanning surface, probe parameter and distribution, equipment sensitivity set-up, scan increment, scanning increment, pulse repetition frequency, signal averaging, video smoothing, zones and beam coverage, scanning mode, scanning velocity, transverse flaw testing plan, where necessary;
- (5) testing identification requirements, testing operation procedures;
- (6) data recording requirements.

### 2.3.3 Technique verification requirements

2.3.3.1 Technique verification is to be witnessed by ISC surveyors on site.

2.3.3.2 Testing personnel are to use testing equipment as well as technique parameters and set-up used for actual testing on the simulated block to demonstrate operation and data interpretation.

2.3.3.3 The test results are to comply with the following requirements:

- (1) test data is satisfactory and valid;
- (2) all expected flaws in the block are detected;
- (3) when sizing flaws according to the measuring method in the technique document, the measured size is not to be less than the actual size.

## CHAPTER 3 SELECTION AND SET-UP OF TESTING PROCEDURE PARAMETERS

### 3.1 Test area

#### 3.1.1 Test area

3.1.1.1 The test area is to include the weld and heat-affected zone (HAZ). The width of the HAZ is to be the actual measurement according to the corresponding procedural approval or 10 mm outside both sides of the fusion line, whichever is greater, as shown in Figure 3.1.1.

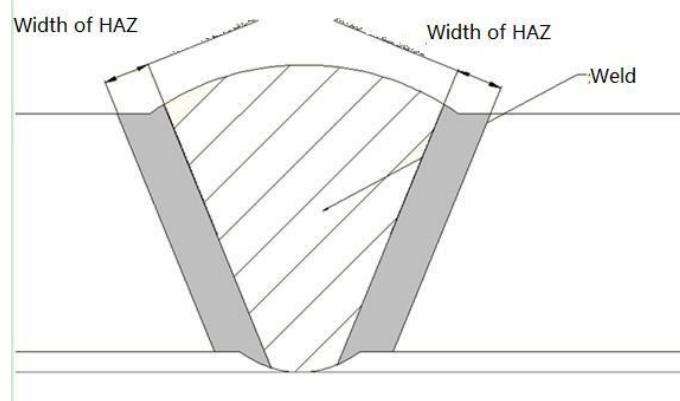

**Figure 3.1.1 Test Area**

3.1.1.2 Under any circumstance it is to be guaranteed that TOFD and PAUT combined inspection can cover the complete test area. Otherwise additional tests are required.

### 3.2 Design of testing procedures

#### 3.2.1 Testing procedures

Non-parallel scan is to be used for TOFD testing and PAUT testing is to be carried out on one surface at both sides. These two testing techniques can be carried out simultaneously or separately.

#### 3.2.2 Testing for transition welds

Testing for transition welds may be carried out in accordance with Appendix A.

#### 3.2.3 TOFD set-up

During TOFD testing, probes may be selected and zones may be marked according to Table 3.2.3.

**TOFD Testing Zones and Recommendation for Probe Selection**

**Table 3.2.3**

Thickness of object(t) mm	Number of zones	Depth range mm	Nominal frequency MHz	Beam angle $\alpha$ (°)	Element diameter mm
$30 \leq t \leq 50$	1	$0 \sim t$	$5 \sim 3$	$70 \sim 60$	$3 \sim 6$
$50 < t \leq 100$	2	$0 \sim 0.4t$	$7.5 \sim 5$	$70 \sim 60$	$3 \sim 6$
		$0.4t \sim t$	$5 \sim 3$	$60 \sim 45$	$6 \sim 12$

#### 3.2.4 PAUT set-up

3.2.4.1 During PAUT testing, the probe frequency is to be from 2 MHz to 5 MHz.

3.2.4.2 PAUT testing is to use S-scan the main beam of which is to completely cover the dead zone of the TOFD technique. The position of the PAUT probes and the scope of the beam

coverage may be determined by beam coverage simulation software or by means of drawing. The dead zone of the TOFD testing may be determined by calculation according to theoretical formula or actual measurement.

### 3.2.5 Transverse flaw testing

When considering transverse flaw testing, special testing methods with regard to transverse flaws are to be added, e.g. TOFD inclined scan, routine ultrasonic or phased array ultrasonic inclined parallel scan etc.

## CHAPTER 4 TESTING REQUIREMENTS

### 4.1 General requirements

#### 4.1.1 Test timing

4.1.1.1 Where heat treatment is required, testing is to be carried out after completion of the heat treatment.

4.1.1.2 Testing is to be carried out at least 24h after completion of the welding.

4.1.1.3 For quenched and tempered steel with the minimum yield strength greater than or equal to 420 N/mm<sup>2</sup>, the NDT of the weld is to be carried out 48h after welding.

#### 4.1.2 Requirements for the scanning surface

4.1.2.1 The scanning surface on which the probes move is to be machined even and be free of weld spatter, rust, grease as well as other foreign matter that may interfere with the transmission of the acoustic energy.

4.1.2.2 For the polished surface, the surface roughness Ra is not to be greater than 12.5  $\mu$ m.

4.1.2.3 Where there are relatively large pits on the scanning surface, patch welding is to be carried out and the patched area is to be made flush with the adjacent base metal.

#### 4.1.3 Testing of base metal

4.1.3.1 For the testing of important objects, straight probes are to be used to test the base metal area which may affect beam transmission to identify potential flaw that may affect the test result. Similarly, if test personnel have doubt about test results, the method above also applies.

4.1.3.2 When the straight probes are testing the base metal, echo of the object is to occur twice as a minimum. The second echo in way of position without flaw is set as 100% full screen height to test sensitivity. For areas where the flaw signal amplitude is more than 20% or where the echo disappears, the surface of the object is to be marked and recorded.

#### 4.1.4 Temperature

4.1.4.1 When using conventional probes and couplants, the surface temperature of the object under examination is to be in the range from 0°C to 50°C. Otherwise, special probes and specialized couplants are to be used. Set-up and calibration are to be carried out in the actual testing temperature.

4.1.4.2 The temperature for calibration is to be within 20°C from the temperature for actual testing.

#### 4.1.5 Requirements for scanning marks

4.1.5.1 The testing position is to give permanent reference position according to information on the weld and structure to facilitate the traceability and reproducibility of the data.

4.1.5.2 Specific rules are to be developed for the scanning direction of the weld. For example, the deck weld is to be scanned from the port side to the starboard side, the side weld from top to bottom, the longitudinal weld from stem to stern, etc. Those contents are to be specified in the testing procedures.

4.1.5.3 During scanning, a reference line is to be drawn according to the weld centerline with scanning motion marked so as to ensure that the probes move along the expected scanning plan.

### 4.2 Equipment set-up

#### 4.2.1 Scan increment

Scan increment is to be set as 1 mm.

#### 4.2.2 Scanning velocity

Scanning velocity is to be less than or equal to the maximum scanning velocity  $V_{\max}$  which may be calculated according to the following formula:

$$V_{\max} = \frac{PRF}{n_p + N \times n_t} \Delta X$$

where:

- $V_{\max}$ —the maximum scanning velocity, in mm/s;
- $PRF$ —the pulse repetition frequency of the excitation probe, in Hz;
- $\Delta x$ —the pre-set scan increment, in mm;
- $N$ — the pre-set number of signal averaging;
- $n_p$ — number of PAUT beam;
- $n_t$ — number of TOFD beam.

#### 4.2.3 Time window setting

4.2.3.1 For testing using only one setup of TOFD, the time window is to be set to start at least 0.5  $\mu$ s prior to the time of arrival of the lateral wave, and extend at least 0.5  $\mu$ s beyond the first mode-converted back-wall signal.

4.2.3.2 If more than one setup of TOFD is used, the A-scan signal of the first zone is to display 0.5  $\mu$ s prior to the time of arrival of the lateral wave and the display of the last zone is to end 0.5  $\mu$ s beyond the first mode-converted back-wall signal. The time windows are to overlap by at least 25 % of the depth range.

4.2.3.3 For PAUT testing, the scope of displaying is at least to include the focused testing area.

#### 4.2.4 PAUT focus setting

4.2.4.1 The angle increment of PAUT S-scan is not to be greater than 1°.

4.2.4.2 PAUT S-scan is recommended to focus based on depth. Where only the first wave is used, the focus depth is to be set as 1.2t; where both first and second waves are used or only second wave is used, the focus depth is to be set as 2.2t, where t is the nominal thickness of the base metal.

4.2.4.3 To improve the image quality, dynamic depth focusing (DDF) is recommended.

#### 4.2.5 Scanning coverage and data recording length

4.2.5.1 If a weld is scanned in more than one part, an overlap of at least 20 mm between the adjacent scans is required. When scanning circumferential welds, the same overlap is required for the end of the last scan with the start of the first scan.

4.2.5.2 The data recording length set for the equipment in actual testing is at least to be greater than the actual scanning length by 20 mm.

### 4.3 TOFD system configuration

#### 4.3.1 TOFD sensitivity setting

4.3.1.1 For testing using only one setup of TOFD, the sensitivity can be set on the test object directly. The amplitude of the lateral wave in parts free of flaw is to be between 40% and 80% full screen height (FSH) as the benchmark sensitivity.

4.3.1.2 For testing using multiple setups of TOFD, reference blocks are to be used to adjust the

sensitivity. Weaker diffracted wave signal on the blocks are adjusted to be between 40% and 80% full screen height (FSH) as the benchmark sensitivity.

4.3.1.3 After the completion of the sensitivity setting, the electrical noise signal is not to be greater than 5% full screen height (FSH).

#### 4.3.2 TOFD depth calibration

Prior to testing, the TOFD testing system is to be depth calibrated according to PCS and sound velocity, and depth corrected where necessary. After calibration and correction, the depth error of the blocks is not to be greater than 0.2 mm.

#### 4.3.3 Coupling compensation correction

4.3.3.1 When blocks are used to adjust sensitivity, the actual testing sensitivity is to be the benchmark sensitivity plus coupling compensation. The correction value is to be obtained by actual measurement.

4.3.3.2 When adjusting sensitivity directly on the actual object, coupling compensation is not required.

### 4.4 PAUT system configuration

#### 4.4.1 General requirements

PAUT configuration and calibration include probe element check, sound velocity testing of the tested material, calibration of wedge delay, sensitivity calibration, addition of TCG curve.

#### 4.4.2 Element check

During each system configuration, elements intended to be used on probes are to be examined. The following requirements are to be satisfied:

- (1) element damage rate in the intended element group is not greater than 10%, and adjacent elements are not allowed to be damaged;
- (2) sensitivity deviation between the intended elements is not greater than 6 dB, and the sensitivity deviation between the adjacent elements is not greater than 3 dB. Elements with deviation greater than 6 dB are counted as damaged elements.

#### 4.4.3 Calibration of wedge delay

Arcs in the reference blocks are to be used to calibrate sound velocity and wedge delay. After calibration, the error of depth and horizontal positioning accuracy on the 3 mm side drilled hole is not to be greater than 1 mm.

#### 4.4.4 Sensitivity and TCG calibration

Drilled holes on the reference blocks are to be used to calibrate sensitivity and TCG of the PAUT system. After calibration, the amplitude consistency error of each position in the tested area is not greater than  $\pm 5\%$  full-screen height.

#### 4.4.5 Coupling compensation correction

4.4.5.1 When blocks are used to adjust sensitivity, the actual testing sensitivity is to be the benchmark sensitivity plus coupling compensation. The correction value is to be obtained by actual measurement.

### 4.5 Test implementation

#### 4.5.1 Scanning deviation

4.5.1.1 During the TOFD testing, the deviation between the actual scanning track and the theoretical one is not to be greater than 10% of the PCS. Refer to Figure 4.5.1.1 for the TOFD

scanning deviation.

4.5.1.2 During PAUT, the deviation between the actual scanning track and the theoretical one is not to cause incompleteness of the beam coverage or too big positioning error.

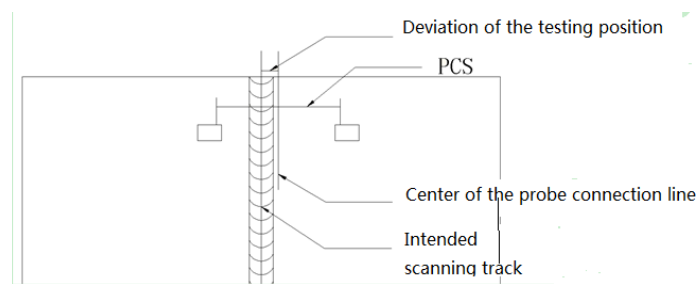

**Figure 4.5.1.1 Illustration of TOFD Scanning Deviation**

4.5.2 Checking of the system

4.5.2.1 Checks are to be performed prior to the examination and on completion of the examination. Where the continuous working duration is relatively long, checks are to be performed at least every 4 h.

4.5.2.2 Checks are to be carried out whenever a system parameter is changed.

4.5.2.3 If a reference block was used for the initial setup, the same reference block is to be used for subsequent checks without coupling compensation. Where the object was used for checking, then subsequent checks are to be carried out at the same position as the initial check.

4.5.3 Scanning length

Single scanning length is not to be greater than 2 m.

4.5.4 Deviation treatment

4.5.4.1 Where there are relatively big deviations in the testing system, settings are to be corrected and previous test positions are to be retested, see Table 4.5.4 for details.

**Allowed Maximum Deviation and Treatment****Table 4.5.4**

Sensitivity	
Deviations $\leq 6$ dB	No action required; data may be corrected by software
Deviations $> 6$ dB	Settings are to be corrected and all tests carried out since the last valid check are to be repeated
Range	
Deviations $\leq 0,5$ mm or 2 % of depth range, whichever is greater	No action required
Deviations $> 0,5$ mm or 2 % of depth range, whichever is greater	Settings are to be corrected and all tests carried out since the last valid check are to be repeated
Encoder	
Deviations within 500 mm $\leq 1\%$	No action required
Deviations within 500 mm $> 1\%$	Settings are to be corrected and all tests carried out since the last valid check are to be repeated

## CHAPTER 5 TEST DATA ANALYSIS AND INTERPRETATION

### 5.1 Evaluation of data validity

#### 5.1.1 Data requirements

5.1.1.1 Valid data are to comply with the following requirements at the same time. Where the data are invalid, collection is to be carried out again:

- (1) display range of A-scan data complies with the requirements in 4.2.3;
- (2) data collection length is same as the actual weld length;
- (3) data losing is not to exceed 5% of the total data, and adjacent data are not allowed to be lost continuously;
- (4) in the scanning range characteristic wave loss greater than 12 dB is not allowed to occur. In PAUT, the whole scanning length is not allowed to have obvious background noise reduction or other flawed coupling characteristics.

### 5.2 Relevant indications and irrelevant indications

#### 5.2.1 General requirements

5.2.1.1 Information on weld conditions is divided into relevant indications and irrelevant indications according to structure.

#### 5.2.2 Classification of TOFD flaws

For TOFD technical testing, relevant indications may be classified as either surface-breaking flaw or embedded flaw.

5.2.2.1 Surface-breaking flaw can be further classified as scanning surface flaw, opposite surface flaw or through-wall flaw. In TOFD testing, surface-breaking flaw generally causes the distortion or interruption of the lateral wave or the back-wall reflection, and only the signals of the lower tip or upper tip are shown in the image, of which the signal of the lower tip is of the same phase as that of the lateral wave and the signal of the upper tip is of the opposite phase as that of the lateral wave.

5.2.2.2 For TOFD testing, embedded flaws can be classified as point-like flaws, elongated flaws with no measurable height and elongated flaws with a measurable height according to the image pattern. TOFD indications of embedded flaws usually do not disturb the lateral wave or the back-wall reflection.

#### 5.2.3 Typical TOFD image

Refer to Appendix B for typical TOFD flaw image.

## CHAPTER 6 ASSESSMENT OF FLAWS AND QUALITY CLASSIFICATION

### 6.1 General requirements

#### 6.1.1 General

The quality of weld consists of levels 1, 2 and 3, corresponding to requirements ranging from high ones to low ones. The acceptance level of important areas of ships is level 1 while that of areas other than important areas is level 2. Important areas are given in 7.1.7, Chapter 7 of the Guidelines for Inspection of Hull Welds.

#### 6.1.2 General requirements for assessment of flaws

6.1.2.1 Flaws are mainly assessed in accordance with TOFD testing results. If a same flaw is detected by both TOFD and PAUT, the latter may be used as an auxiliary location and characteristics tool.

6.1.2.2 If a same flaw is detected by both TOFD and PAUT and the indication of PAUT signal is complete, the PAUT signal is used for location and the TOFD image is used for sizing purpose.

6.1.2.3 If a flaw not indicated by TOFD testing results is detected by PAUT, the PAUT data is used as the basis for location, sizing and characteristics purposes for such flaw.

### 6.2 Assessment of flaws of TOFD

#### 6.2.1 Measurement of the length of flaws

6.2.1.1 The length of flaw means the distance between projections of the flaw along the X coordinate, see  $l$  in Figure 6.2.1.

6.2.1.2 For the length measurement by TOFD, a parabolic fitting pointer is to be used to measure the start and end positions of the flaw along the X coordinate. The start position of flaw is recorded as the position of flaw. The difference between the end and start positions is recorded as the length of flaw.

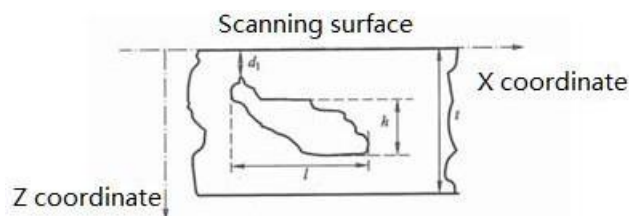

Figure 6.2.1 Length, Depth and Height in TOFD

#### 6.2.2 Measurement of the depth of flaws

6.2.2.1 The depth of flaw means the minimum distance between the upper tip of flaw and the scanning surface, see  $d_1$  in Figure 6.2.1.

6.2.2.2 For a flaw with undistinguishable height, the depth of flaw means the distance between the indication of flaw and the scanning surface.

6.2.2.3 For a flaw with its own height, the depth of flaw means the distance between the upper tip of flaw and the scanning surface.

6.2.2.4 The depth of scanning surface-breaking flaws is 0.

#### 6.2.3 Measurement of the height of flaws

6.2.3.1 The height of flaw means the maximum distance between projections of the flaw along the Z coordinate at certain position along the X coordinate, see  $h$  in Figure 6.2.1.

6.2.3.2 For surface-breaking flaws, the height of flaw means the maximum distance between the upper (lower) tip of flaw and the back wall (scanning surface).

### 6.3 Assessment of flaws of PAUT

#### 6.3.1 Measurement of the length of flaws

6.3.1.1 The use of absolute sensitivity method where the amplitude is reduced to the evaluation level is recommended to measure the length of flaws. The start position is recorded as the position of flaw. The difference between the end and start positions is recorded as the length of flaw.

When other methods are used to measure the length of flaws, such methods are to be indicated in the procedure specifications and it is to be demonstrated by procedure approval that such methods will not lead to smaller estimation of flaws.

#### 6.3.2 Measurement of the depth and horizontal position of flaws

6.3.2.1 The position of the maximum wave amplitude of flaws along the Z coordinate as well as its position along the Y coordinate are defined as the depth and horizontal position of flaws, see Figure 6.3.2.1.

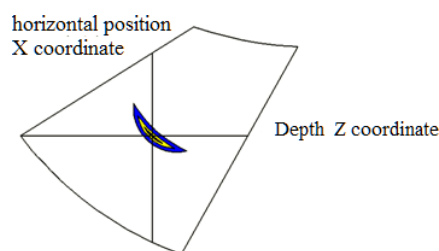

**Figure 6.3.2.1 Depth and Horizontal Position of Flaws in PAUT**

#### 6.3.3 Measurement of the height of flaws

6.3.3.1 Tip diffraction or -6dB method may be used to measure the height of flaws.

6.3.3.2 Height measurement methods are to be indicated in the procedure specifications and it is to be demonstrated by procedure approval that such methods will not lead to smaller estimation of flaws.

### 6.4 Quality classification

#### 6.4.1 General requirements

The nature of flaws is to be judged in conjunction with the results of PAUT and TOFD testing.

6.4.1.1 Any flaw deemed possibly as crack, lack of fusion, lack of penetration or other hazardous flaw is to be assessed as level 3.

6.4.1.2 All transverse flaws are assessed as level 3.

6.4.1.3 With regard to TOFD testing results, flaws must be assessed based on length and height of flaws. With regard to PAUT testing results, flaws may be assessed based on length and height of flaws or based on length and echo amplitude of flaws.

#### 6.4.2 TOFD testing quality classification

6.4.2.1 Quality classification of individual flaws of TOFD

Non-hazardous individual flaws detected by TOFD are to be assessed in accordance with the requirements of Table 6.4.2.1.

**Quality Classification of TOFD Testing**

**Table 6.4.2.1**

Acceptance level	Quality level in ISO5817	Thickness range of base metal (mm)	Maximum acceptable length if $h < h_2$ or $h_3$ $L_{max}$ (mm)	Maximum acceptable height if $L \leq L_{max}$		Maximum acceptable height if $L > L_{max}$ $h_1$ (mm)
				Surface-breaking flaws $h_3$ (mm)	Embedded flaws $h_2$ (mm)	
Level 1	Level B	$30 < t \leq 50$	$0.75t$	2	3	1
		$50 < t \leq 100$	40	2.5	4	2
Level 2	Level C	$30 < t \leq 50$	$t$	2	4	1
		$50 < t \leq 100$	50	3	5	2
Level 3	If the limits of level 2 are exceeded					

\* Note: If acceptance criteria other than those specified in the Guidelines are used, they are to be agreed by ISC.

#### 6.4.2.2 Requirements for judging grouped flaws of TOFD

If the distance between two individual flaws along the direction of weld length is less than the length  $l$  of the longer flaw and the distance along the direction of depth is less than the height  $h$  of the higher flaw, it is to be treated as individual flaw and the total length  $lg$  is defined as the sum of the lengths of the individual flaws plus the distance between them. If two individual flaws overlap along the direction of length, the total height ( $hg$ ) is defined as the sum of the heights of the individual flaws plus the distance between them. If two individual flaws do not overlap along the direction of length, the total height ( $h'g$ ) is to be calculated in accordance with the higher flaw, see Figure 6.4.2.2.

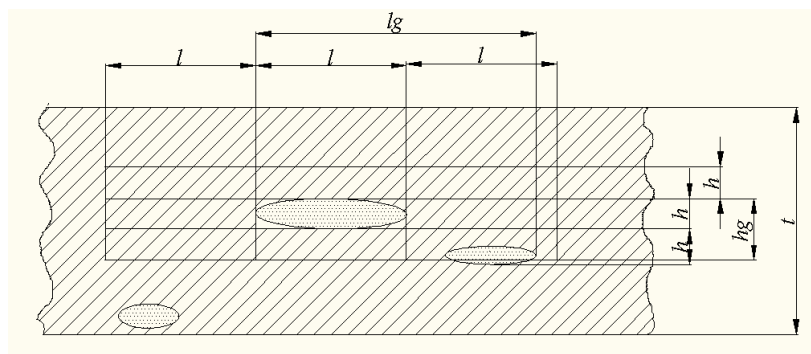

**Figure 6.4.2.2 Grouped Flaws**

#### 6.4.2.3 Classification of cumulative length of TOFD flaws

With regard to individual flaws not exceeding the specified limits, the cumulative length of flaws is to be calculated and subject to quality classification in accordance with the requirements of Table 6.4.2.3.

**Level of Cumulative Length of Flaws of TOFD** **Table 6.4.2.3**

Acceptance level	Quality level in ISO5817	Acceptance requirements for cumulative flaws
Level 1	Level B	Within the range of any 12t, not exceeding 3.5t, maximum 150 mm
Level 2	Level C	Within the range of any 12t, not exceeding 4t, maximum 200 mm
Level 3	If the limits above are exceeded	

6.4.3 PAUT testing quality classification for acceptance criteria based on flaw length and height

6.4.3.1 Quality classification of individual flaws

**Quality Classification of Individual Flaws** **Table 6.4.3.1**

Acceptance level	Quality level in ISO5817	Thickness range of base metal (mm)	Maximum acceptable length if $h < h_2$ or $h_3$ $L_{max}$ (mm)	Maximum acceptable height if $L \leq L_{max}$		Maximum acceptable height if $L > L_{max}$ $h_1$ (mm)
				Surface-breaking flaws $h_3$ (mm)	Embedded flaws $h_2$ (mm)	
Level 1	Level B	$30 \leq t \leq 50$	t	2	4	1
		$50 < t \leq 100$	50	3	5	2
Level 2	Level C	$30 \leq t \leq 50$	1.5t (maximum 60)	2.5	4.5	2
		$50 < t \leq 100$	60	4	6	3
Level 3	If the limits of level 2 are exceeded					

6.4.3.2 Requirements for judging grouped flaws

If the distance between two individual flaws along the direction of weld length is less than the length  $l$  of the longer flaw and the distance along the direction of depth is less than the height  $h$  of the higher flaw, it is to be treated as individual flaw and the total length  $lg$  is defined as the sum of the lengths of the individual flaws plus the distance between them, the total height is defined as the sum of the heights of the individual flaws plus the distance between them., see Figure 6.4.3.2.

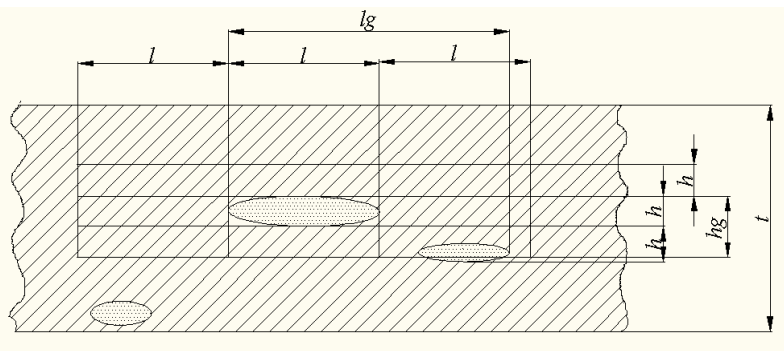

**Figure 6.4.3.2 Grouped Flaws**

### 6.4.3.3 Classification of cumulative length of flaws

With regard to individual flaws not exceeding the specified limits, the cumulative length of flaws is to be calculated and subject to quality classification in accordance with the requirements of Table 6.4.3.3.

**Level of Cumulative Length of Flaws of PAUT** **Table 6.4.3.3**

Acceptance level	Quality level in ISO5817	Acceptance requirements for cumulative flaws for plate thickness not greater than 50 mm	Acceptance requirements for cumulative flaws for plate thickness greater than 50 mm
Level 1	Level B	Within the range of any 12t, not exceeding 4t, maximum 200 mm	Not exceeding 10% of weld total length within the range of weld, maximum 600 mm
Level 2	Level C	Within the range of any 12t, not exceeding 5t, maximum 225 mm	Not exceeding 10% of weld total length within the range of weld, maximum 700 mm
Level 3	If the limits above are exceeded		

### 6.4.4 PAUT testing quality classification for acceptance criteria based on flaw length and echo amplitude

#### 6.4.4.1 Quality classification of individual flaws

**Quality Classification of Individual Flaws** **Table 6.4.4.1**

Acceptance level	Quality level in ISO 5817	Wave height of flaws	Length of flaws	Recording level	Assessment level
Level 1	Level B	Ø3-6dB~Ø3	Not greater than 0.5t	Ø3-4dB	Ø3-14dB
		Ø3-10dB~Ø3-6dB	Not greater than t	Ø3-10dB	Ø3-14dB
		Ø3-14dB~Ø3-10dB	Not greater than 1.2t	Ø3-14dB	Ø3-14dB
Level 2	Level C	Ø3-2dB~Ø3+4dB	Not greater than 0.5t	Ø3	Ø3-10dB
		Ø3-6dB~Ø3-2dB	Not greater than t	Ø3-6dB	Ø3-10dB
		Ø3-10dB~Ø3-6dB	Not greater than 1.8t	Ø3-10dB	Ø3-10dB
Level 3	If the limits above are exceeded				

\* Note: If acceptance criteria other than those specified in the Guidelines are used, they are to be agreed by ISC.

#### 6.4.4.2 Requirements for judging grouped flaws

If the distance  $d_x$  between two individual flaws along the direction of scanning is less than 2 times the length  $l_1$  of the longer flaw and the distances between projections of two flaws at the horizontal and depth positions are both less than  $t/2$  or 10 mm (whichever is lesser), it is to be treated as individual flaw and the total length  $l_{12}$  is defined as the sum of the lengths of the individual flaws

plus the distance between them, see Figure 6.4.4.2.

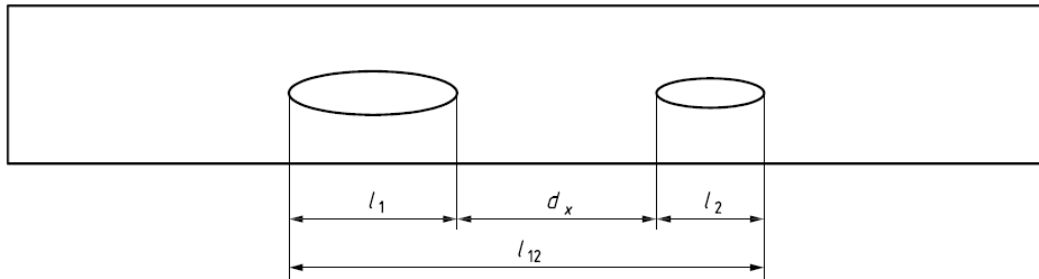

**Figure 6.4.4.2 Grouped Flaws**

#### 6.4.4.3 Classification of cumulative length of flaws

With regard to flaws with wave amplitude exceeding the recording level, the cumulative length of flaws is to be calculated. Within the range of any  $6t$ , the cumulative length of flaws is to be subject to quality classification in accordance with the requirements of Table 6.4.4.3.

**Level of Cumulative Length of Flaws Table 6.4.4.3**

Acceptance level	Quality level in ISO5817	Acceptance requirements for cumulative flaws
Level 1	Level B	1.2t
Level 2	Level C	1.8t
Level 3	If the limits above are exceeded	

#### 6.4.5 Point-like flaws

For all acceptance methods and levels, point-like flaws are not included in the calculation of cumulative length, but point-like flaws within any length of 150 mm are not to exceed 1.2t, where the unit of t is mm. E.g., for welds with the thickness of base metal of 50 mm, the number of point-like flaws is not to exceed 60 within any length of 150 mm.

#### 6.4.6 Length reduction

For calculation of cumulative length or point-like flaws, if the weld length is less than  $6t$ ,  $12t$  or 150 mm of Section 6.4, the corresponding acceptance criteria are to be reduced proportionally. If the limit of cumulative length after reduction is less than the limit of individual flaws, the latter is to prevail.

6.4.7 For all acceptance methods, if the same weld is tested by using multiple set-ups, the requirements for the cumulative length of all flaws may be relaxed to 1.5 times the normal requirements.

## **CHAPTER 7 TESTING RECORDS AND REPORTS**

### **7.1 Testing records and reports**

#### 7.1.1 Testing reports

The test report is at least to include the following information specified in this section, and for the sample, please refer to Appendix C.

7.1.1.1 Details of the object under test, including the name of project, name of object under test, type, material, condition, type of weld groove, etc.

7.1.1.2 Name of hardware, including the name and identification number of equipment, the name and identification number of probes, the identification number of encoders, the name and identification number of testing blocks, etc.

7.1.1.3 Parameter setting, including reference standards, testing level, sensitivity setting method, size of probe element (TOFD), wedge angle (TOFD), PCS value (TOFD), average time (TOFD), probe frequency (TOFD and PAUT), probe aperture (PAUT), wedge angle (PAUT), scanning type (PAUT), range of angle (PAUT), scan increment (PAUT), position of the probe in relation to the weld (PAUT), diagram of wave beam coverage (PAUT), resolution of encoder, verification data of testing block, etc.

7.1.1.4 Testing content, including name of setting, testing type, testing time, surface condition, couplant, testing temperature, scan increment, testing position, scanning direction and numbering method, name, signature, level, certificate number of testing personnel and testing date, etc.

7.1.1.5 Assessment of flaws, including the name and edition of data interpretation software in use, reference standards, acceptance levels, number of repairs, data processing function in use, position of flaw, length of flaw, depth of flaw (TOFD and PAUT), height of flaw (TOFD), distance between the flaw and the weld centerline (PAUT), whether satisfactory or not, scanned image of flaw exceeding standards, name, signature, level of data interpretation and review personnel, date, etc.

### **7.2 Storage and filing of testing data**

#### 7.2.1 Storage of testing data

7.2.1.1 The testing data is to be stored in the exclusive storage media for long term.

7.2.1.2 The hard copy of testing report is to be kept for long term after being signed by personnel responsible for preparing and reviewing such report respectively.

7.2.1.3 The testing data and reports are to be kept for a period not less than the service life of the tested objects.

## Appendix A Testing for Transition Welds

### A1 Testing from the flush surface

A1.1 Testing is to be carried out from the flush surface insofar as practicable as shown in Figures A1.1(a) and A1.1(b).

A1.2 For the setting of TOFD testing, it is the same as that for butt welds of equal thickness. The thickness of the thinner plate is taken as plate thickness during the design of procedures.

A1.3 For PAUT testing, secondary wave testing is not preferable due to the existence of scarf on the side of the thicker plate and the first wave mainly covers the lower surface. The first wave and second wave are to be used respectively to cover the back wall and scanning surface areas on the side of the thinner plate.

A1.4 The test is to be carried out in accordance with the texts of the Guidelines.

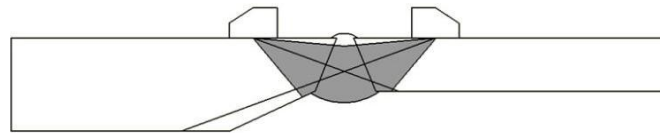

Figure A1.1(a) TOFD Testing From the Flush Surface

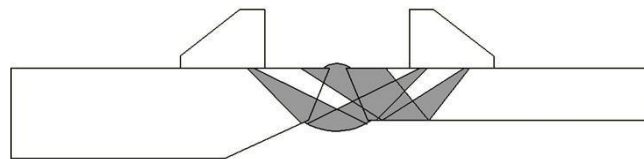

Figure A1.1(b) PAUT Testing From the Flush Surface

### A2 Testing from the scarfing surface

A2.1 If it is only possible to carry out testing from the scarfing surface, testing may be carried out from the scarfing or flat surface as shown in Figure A1.2(a).

A2.2 TOFD testing from the scarfing surface may lead to expansion of dead zone of testing as well as increase of positioning and quantitative deviation.

A2.3 PAUT testing by first and secondary waves is at least to be carried out on the side of the flat surface as shown in Figure A1.2(b).

A2.4 PAUT is to totally cover the dead zone of TOFD testing. The size of dead zone is to be measured by making special testing blocks of dead zone.

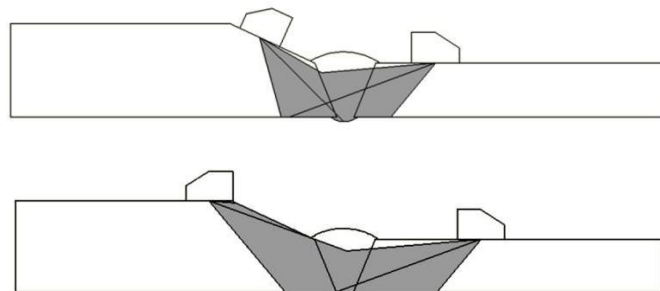

**Figure A1.2(a) TOFD Testing From the Scarfing Surface**

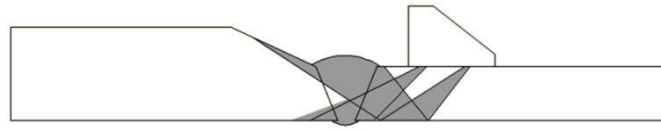

**Figure A1.2(b) PAUT Testing From the Scarfing Surface**

A3 The testing plan is subject to the verification by simulated testing block as specified in 2.1.7.3 of the Guidelines.

## Appendix B Typical TOFD Imaging and Methods of Flaw Measurement

B1 Typical problem with the data quality

B1.1 Improper settings of gain

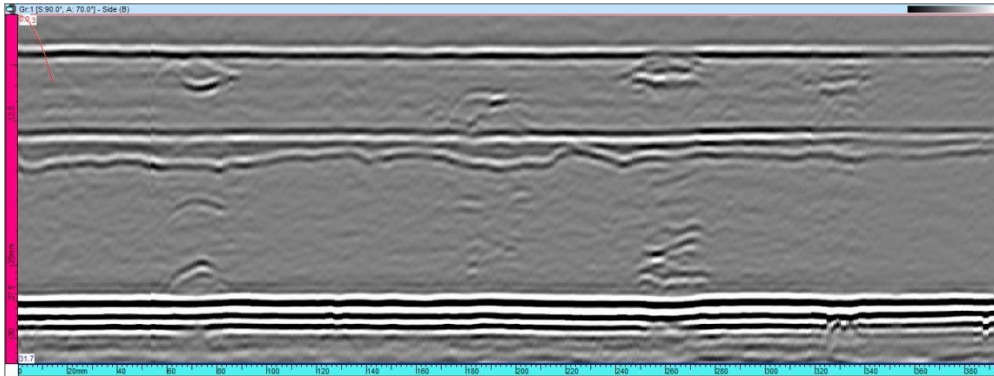

Figure B1.1(a) B-Scan Image of TOFD Testing (Proper Gain)

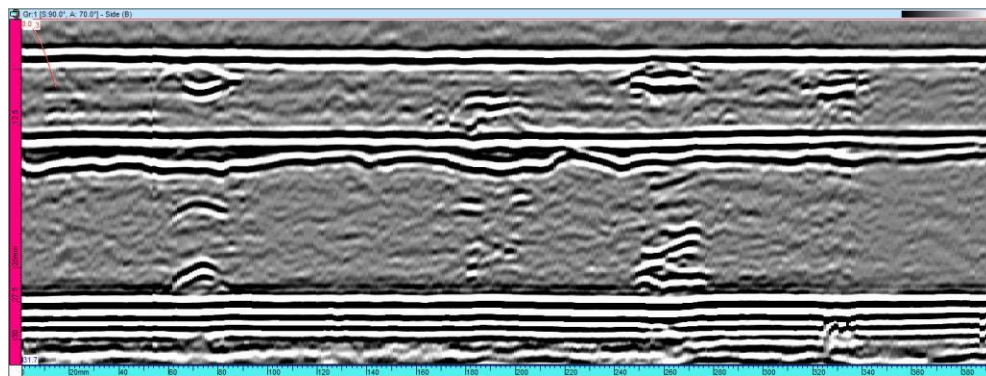

Figure B1.1(b) B-Scan Image of TOFD Testing (Excessively High Gain)

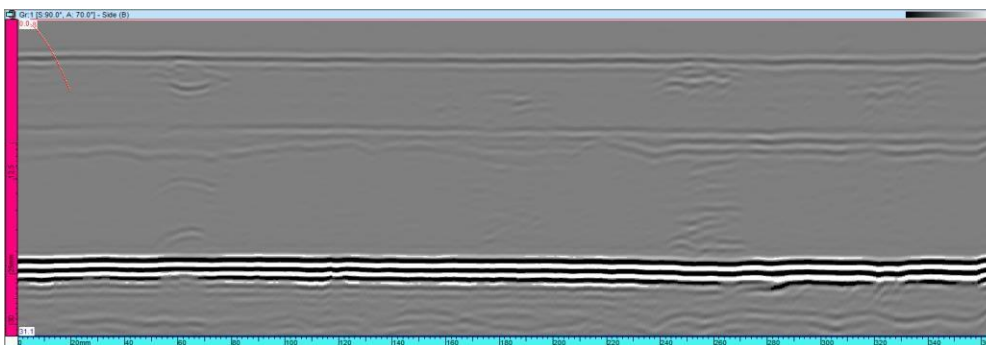
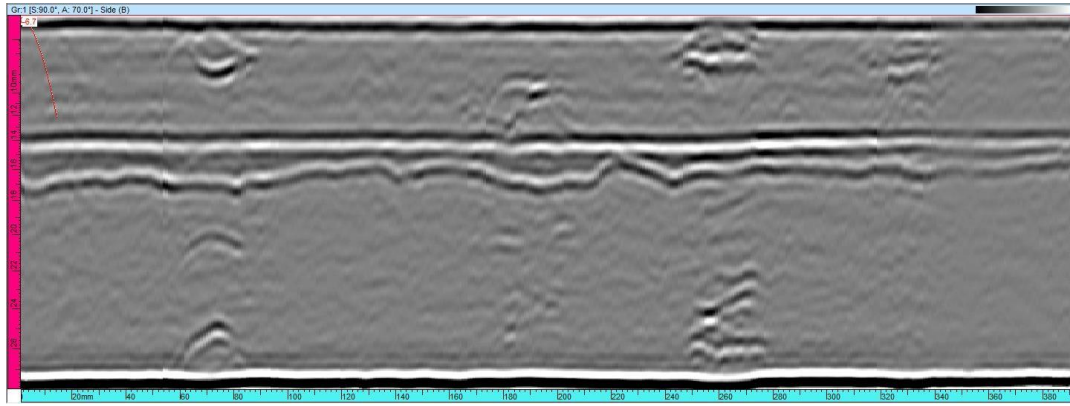

Figure B1.1(c) B-Scan Image of TOFD Testing (Excessively Low Gain)

B1.2 Improper display range



**Figure B1.2 Improper Settings of Display Range (Incomplete Lateral Waves and Conversion Waves)**

B1.3 Abnormal synchronization of time base

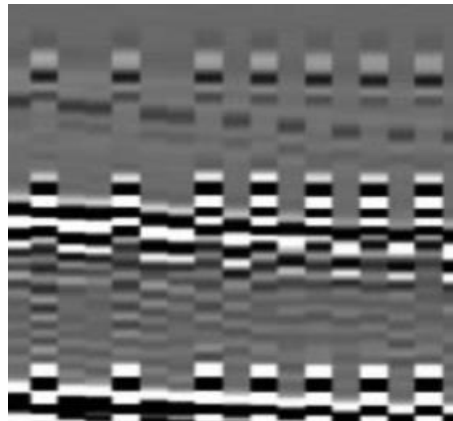

**Figure B1.3 Abnormal Synchronization of Time Base**

B1.4 Data loss and poor coupling

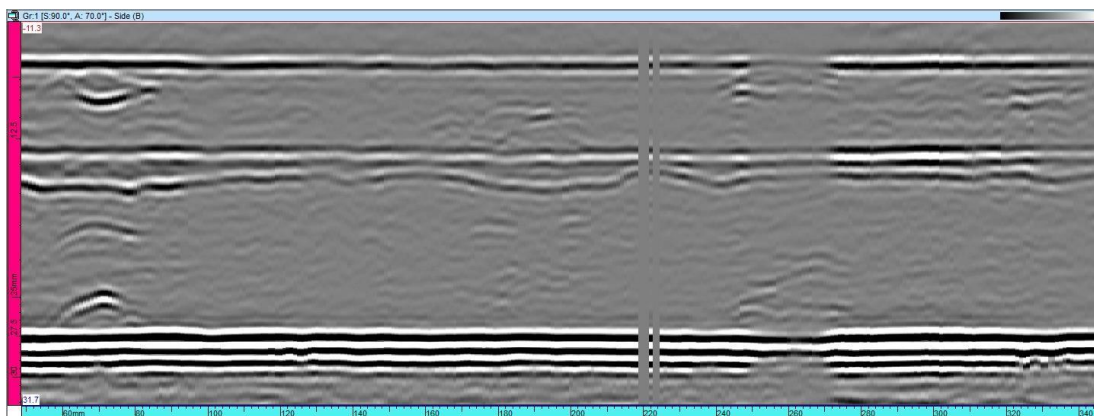

**Figure B1.4 Data Loss and Poor Coupling**

B1.5 Variation in the thickness of the coupling layer

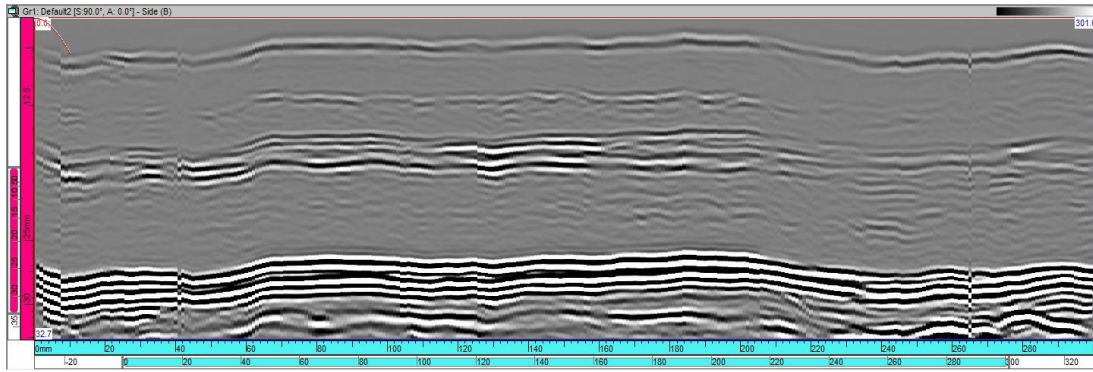

**Figure B1.5 Variation in the Thickness of the Coupling Layer Causing Fluctuations in Lateral Waves**

**B2 Basic features of flaws in TOFD images**

**B2.1 Scanning-surface-breaking flaws**

B2.1.1 Large scanning-surface-breaking flaws will result in obvious breaks of lateral waves, where lower-tip signals of flaws occur with the same phase and time lag;

B2.1.2 Smaller scanning-surface-breaking flaws may also result in concave lateral waves.

B2.1.3 Partial changes of coupling may also cause concave lateral waves in TOFD images.

However, similar changes of the back wall echo would also take place in the same position.

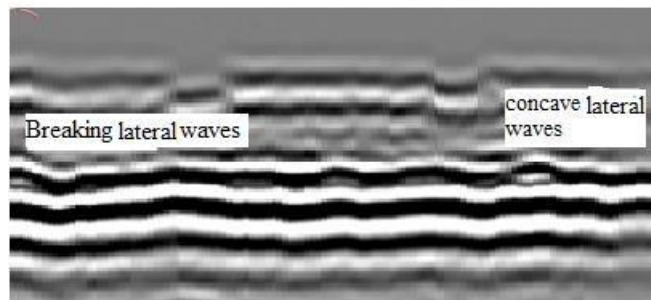

**Figure B2.1(a) Scanning-Surface-Breaking Flaws**

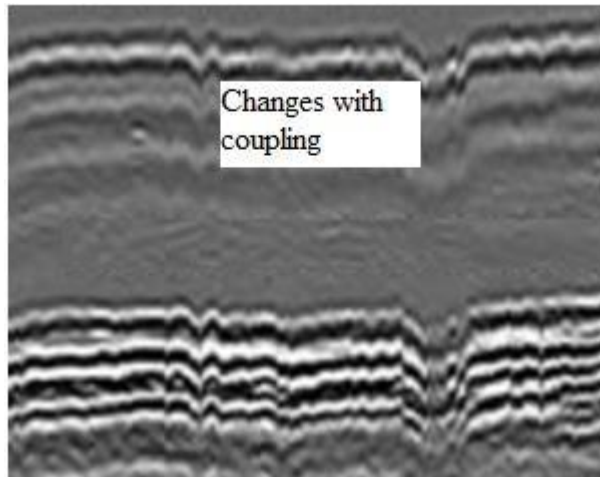
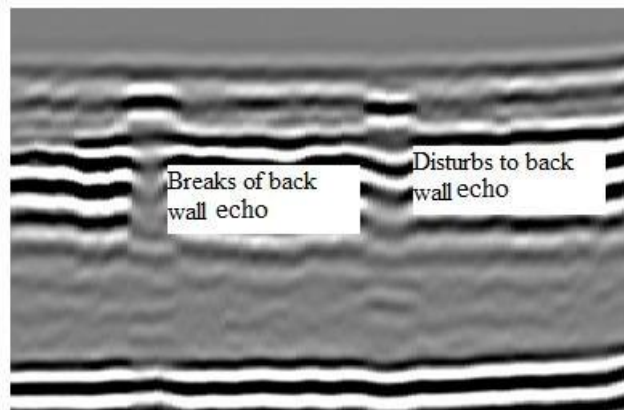

**Figure B2.1(b) Changes of Coupling**

**B2.2 Back-wall-breaking flaws**

B2.2.1 Large back-wall-breaking flaws will break the back wall echo and result in an upper-point signal of flaws with a phase opposite to lateral waves between lateral waves and the back wall echo.

B2.2.2 Under normal conditions, back-wall-breaking flaws will not break the back wall echo, but reduce or disturb them and result in an upper-point diffraction signal of flaws.

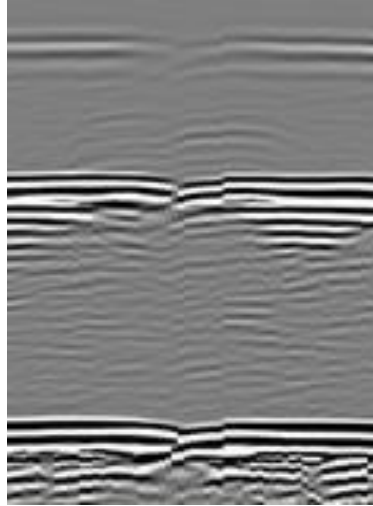

**Figure B2.2 Back-Wall-Breaking Flaws**

**B2.3 Through-wall flaws (openings of both sides)**

B2.3.1 Through-wall flaws mainly feature the reduction or elimination of lateral waves and back wall echoes at the same time and sometimes many arced diffraction signals with depth.

B2.3.2 Partial poor coupling may also have similar features, but there won't be any arced diffraction signal with depth or signal at the flaw edge.



**Figure B2.3(a) Through-wall Flaws**

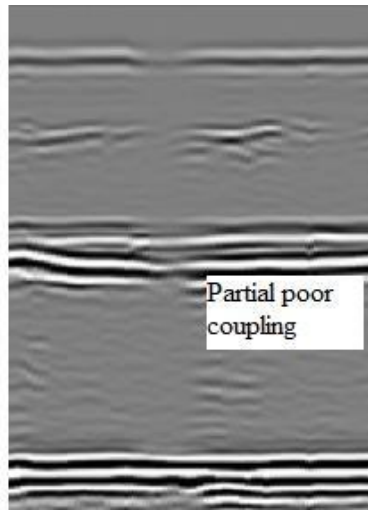
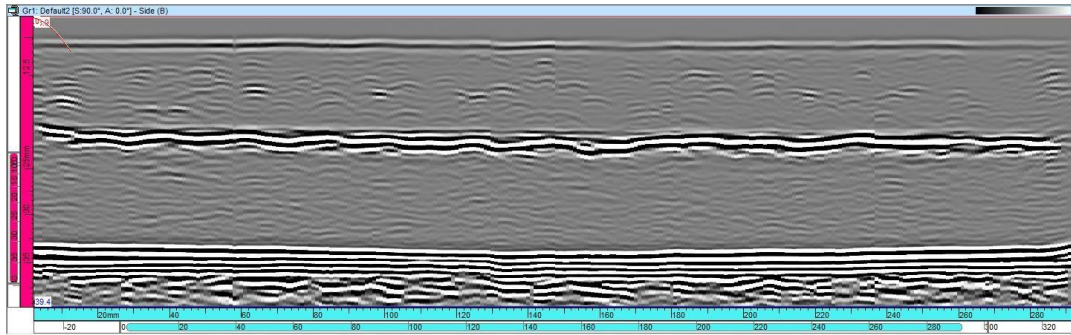

**Figure B2.3(b) Partial Poor Coupling**

#### B2.4 Embedded flaws

Embedded flaws usually won't affect lateral waves and back wall echoes and can be divided into point-like flaws, elongated flaws with no measurable height and elongated flaws with a measurable height.

B2.4.1 Point-like flaws are arced hyperbolic curves without a measurable length and height.



**Figure B2.4.1 Point-Like Flaws**

B2.4.2 Elongated flaws with no measurable height have a certain length without a measurable height.

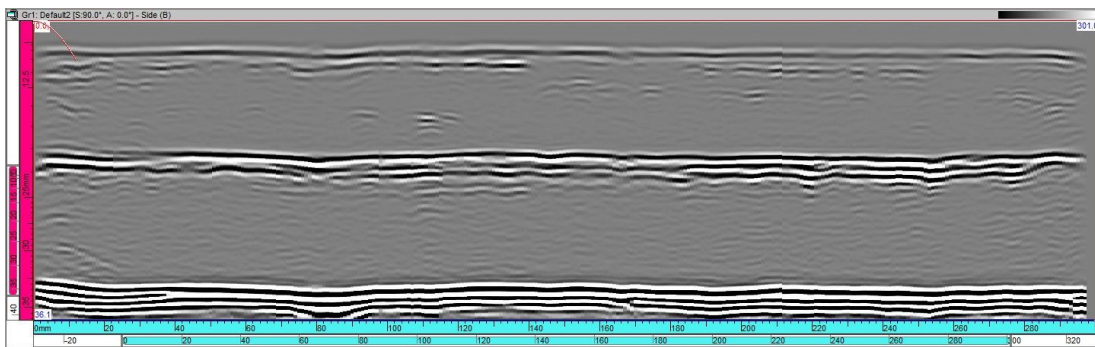

**Figure B2.4.2 Elongated Flaws with No Measurable Height**

B2.4.3 Elongated flaws with a measurable height have a certain length while the phases of the upper and lower tip signals are in opposite directions. The height can be measured by the phase features and positions of the upper and lower tip signals.

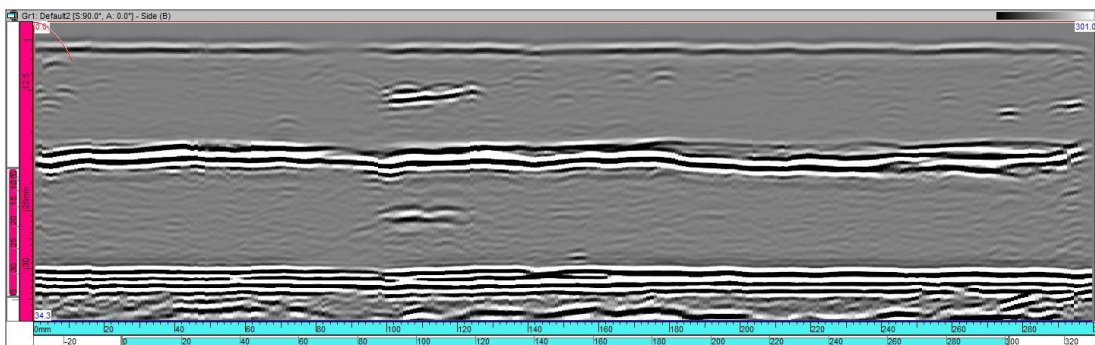
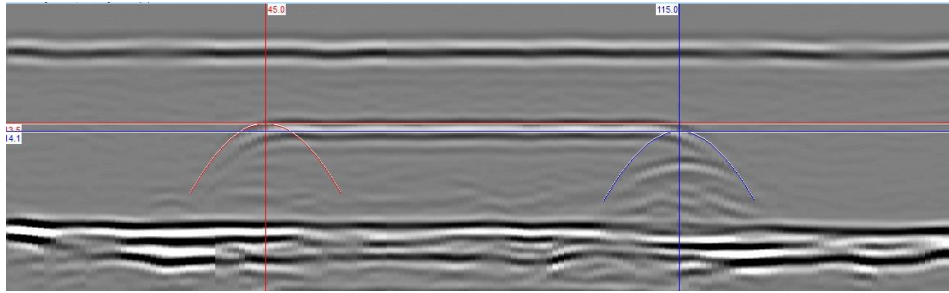

**Figure B2.4.3 Elongated Flaws with a Measurable Height**

### B3 Measurement of flaws

#### B3.1 Length measurement of flaws

B3.1.1 The fitting method of hyperbolic pointer should be adopted for the length measurement of flaws.



**Figure B3.1.1 Use of the Fitting Method of Hyperbolic Pointer in the Length Measurement of Flaws**

B3.1.2 For flaws with an excessively long arc, the fitting method of hyperbolic pointer should start with the 1/3 position from the end of the arc.

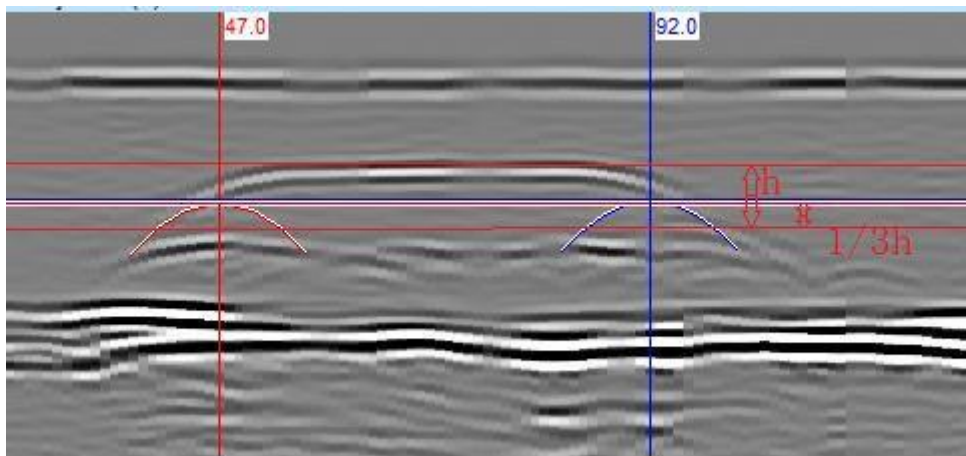

**Figure B3.1.2 Length Measurement of Flaws with Relatively Long Arcs**

B3.2 Depth and height measurement of flaws

B3.2.1 In the measurement of the depth and height of flaws, there are three methods to determine the signal time, namely: the beginning point of signals, the first peak point and the highest peak point.

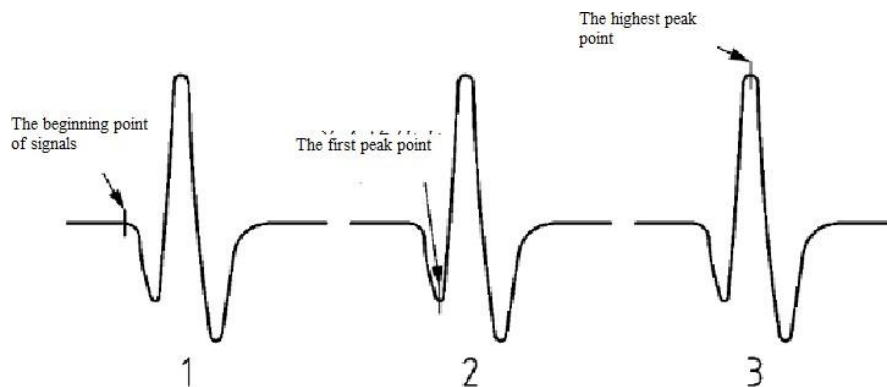

**Figure B3.2.1 Methods of Measuring the Signal Time**

B3.2.2 Under normal conditions, the phase of upper-tip diffraction signals on flaws is opposite

to that of lateral waves but the same as back waves. The phase of the lower-tip diffraction signals is the same as lateral waves and opposite to that of back waves. The length and height measurement of flaws should refer to the phases of the corresponding signals.

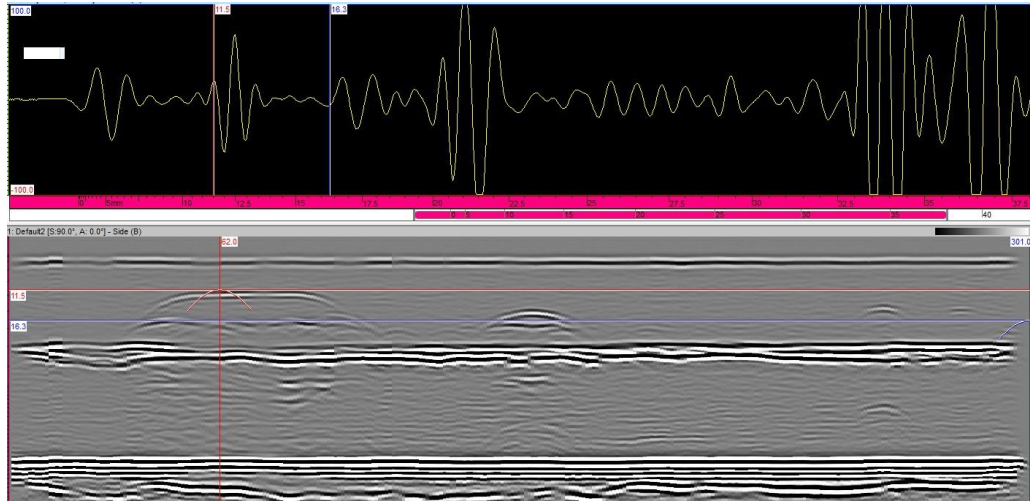

**Figure B3.2.2 Methods for the Depth and Height Measurement of Flaws**

**Appendix C Sample of Combined Inspection Report of TOFD and PAUT**

Combined Inspection Report of Phased Array Ultrasonic Testing (PAUT) and Time of Flight Diffraction(TOFD)														
Name of project					Drawing No. of detection					No. of testing position				
Tested material		Plate thickness		Type of weld groove		Surface condition		Testing time		Couplants		Testing temperature		
PAUT setting							TOFD setting							
Testing equipment		Serial No. of equipment		Type of wedge		Testing equipment		Serial No. of equipment		Type of wedge				
Probe		Serial No. of Probe		Frequency of Probe		Reference Block		Serial No. of block		Testing position				
Reference block		Serial No. of block		Testing position		Encoder		Resolution of encoder						
Encoder		Resolution of encoder		Reference Standards		Testing Levels		Sensitivity						
Reference standards		Testing levels		Sensitivity		Acceptance criteria		Acceptance levels		Scan increment				
Acceptance criteria		Acceptance levels		Scan increment		Analysis software		Software version		Transfer correction				
Analysis software		Software version		Transfer correction		Group 1		Scan Type		Probe		Serial No. of Probe		
Group 1		Scan Type	Aperture	Elements In Use	Angle Range	Increment	Depth of focus							
Group 2		Scan Type	Aperture	Elements In Use	Angle Range	Increment	Depth of focus	Group 2		Scan Type		Probe		
Diagram of combined inspection coverage							Diagram of combined inspection scanning							
Serial no.		Name of testing data				Weld level		Times of testing		Data processing function		Testing conclusions		Remarks
Testing results audited by _____ technology/level: _____ date: _____														



**Combined Inspection Report of Phased Array Ultrasonic Testing (PAUT) and Time of Flight Diffraction(TOFD)(TOFD Attached table)**

Name of testing data									
Data processing function				Weld level		Times of testing		Testing conclusions	

**Details of flaws**

Serial No.	Beginning of flaw (X)	Length of flaw (L)	Horizontal position (Y)	Depth of flaw (D)	Height of flaw (H)	Nature of flaw	Assessment of flaw	Remark	Figure of Definition of Flaw Parameters
1									
2									
3									
4									
5									
6									
7									
8									
9									
10									
11									
12									
13									
14									
15									
16									
17									
18									
19									
20									
Cumulative length of recordable flaws									

Data-collecting personnel \_\_\_\_\_ technology/level: \_\_\_\_\_ date: \_\_\_\_\_  
 Data-analyzing personnel \_\_\_\_\_ technology/level: \_\_\_\_\_ date: \_\_\_\_\_  
 Testing results audited by \_\_\_\_\_ technology/level: \_\_\_\_\_ date: \_\_\_\_\_

**Combined Inspection Report of Phased Array Ultrasonic Testing (PAUT) and Time of Flight Diffraction(TOFD)(TOFD Attached Figure)**

Name of testing data

Testing picture

B-Scan/D-Scan

Data-analyzing personnel \_\_\_\_\_ technology/level: \_\_\_\_\_ date: \_\_\_\_\_

Combined Inspection Report of Phased Array Ultrasonic Testing (PAUT) and Time of Flight Diffraction(TOFD) (PAUT Attached table)										
Name of testing data					Weld level		Times of testing		Testing conclusions	
Details of flaws										
Serial No.	Beginning of flaw (X)	Length of flaw (L)	Horizontal position (Y)	Depth of flaw (D)	Height of flaw (H)	Nature of flaw	Assessment of flaw	Remark	Figure of Definition of Flaw Parameters	
1										
2										
3										
4										
5										
6										
7										
8										
9										
10										
11										
12										
13										
14										
15										
16										
17										
18										
19										
20										
Cumulative length of recordable flaws										
						Data-collecting personnel _____ technology/level: _____ date: _____				
						Data-analyzing personnel _____ technology/level: _____ date: _____				
						Testing results audited by _____ technology/level: _____ date: _____				

**Combined Inspection Report of Phased Array Ultrasonic Testing (PAUT) and Time of Flight Diffraction(TOFD)(PAUT Attached Figure)**

Name of testing data			
Serial No. of flaw		Serial No. of flaw	
S-Scan/E-Scan	A-Scan	S-Scan/E-Scan	A-Scan
B-Scan/C-Scan		B-Scan/C-Scan	
Data-analyzing personnel _____ technology/level: _____ date: _____			